



# Ultramite™ 70 Series

## Fixed End 2- and 3-way Ball Valves

Ultramite™ 70 Series valves are designed to guard against accidental disassembly. The tamper-proof fixed end fittings are welded in place, with the exception of the 7065 Series which are pinned.



### Typical Applications

- High pressure test stands
- Sampling lines
- Instrument lines
- Analyzer labs

### Technical Data

<b>BODY MATERIAL*</b>	316 stainless steel, brass, Monel®
<b>MAXIMUM OPERATING PRESSURE**</b>	6000 psig @ 70° F (414 bar @ 21° C)
<b>OPERATING TEMPERATURE RANGE</b>	-40° F to +350° F (-40° C to +177° C)
<b>ORIFICE SIZES</b>	0.093 to 0.375 (2.3 to 9.5mm)
<b>Cv FACTORS</b>	0.15 to 1.40

\* Consult factory for other materials  
\*\* Depending on individual series.

### Features & Benefits

- Fixed end fittings prevent accidental disassembly, enhancing safety.
- Floating ball provides pressure-assisted sealing and temperature wear compensation for longer valve cycle life and greater value.
- Encapsulated seats extend cycle life, reducing cost of ownership.
- Check seals improve leak tightness thereby increasing seat life.
- Oval trip-proof handle helps prevent accidental actuation. Quarter turn handle provides a visual indication of on/off valve position, improving safety.
- Special High Tolerance NPT Thread

### HOKE Inc.

PO Box 4866 • Spartanburg, SC 29305-4866  
Phone (864) 574-7966 Fax (864) 587-5608  
www.hoke.com • Sales-hoke@circor.com

ball valves

# Ultramite™ 70 Series

## Ultramite™ 7015, 7022 Series (2-way valves)

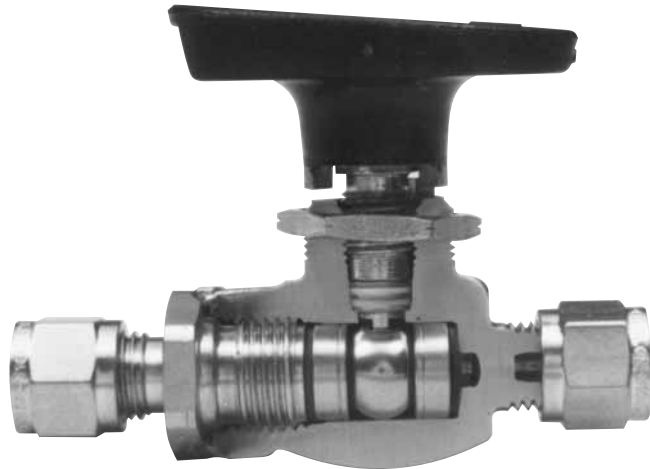

Cv Factors: 0.23 to 1.40

### Typical Applications

- High pressure test stands
- Sampling lines
- Instrument lines
- Analyzer labs

### Technical Data

<b>BODY MATERIAL</b>	316 stainless steel, brass, Monel®
<b>OPERATING PRESSURE RANGE @ 70° F (21° C)</b>	7015: Moderate vacuum* to 6000 psig (414 bar) 7022: Moderate vacuum* to 1500 psig (103 bar)
<b>OPERATING TEMPERATURE RANGE</b>	7015: -40° F to +350° F (-40° C to +177° C) 7022: 0° F to +350° F (-18° C to +177° C)
<b>ORIFICE SIZES</b>	0.093" to 0.250" (2.3 to 6.3mm)
<b>Cv FACTORS</b>	0.23 to 1.40
<b>END CONNECTIONS</b>	1/8" to 3/8" <b>GYROLOK</b> ® 1/4" NPT

\* Moderate vacuum is 10<sup>-3</sup> to 20 torr.

### Features & Benefits

- Fixed end fittings prevent accidental disassembly, enhancing safety.
- Oval trip-proof handle helps prevent accidental actuation. Quarter turn handle provides a visual indication of on/off valve position, providing improved safety.
- Dual encapsulated TFE seats and microfinished ball ensure a bidirectional, leak tight seal. This provides greater valve versatility and operator peace of mind.
- Floating ball provides pressure-assisted sealing and temperature wear compensation for longer valve cycle life and greater value.
- Dyna-Pak® packing provides a leak-tight seal with low operating torque in vacuum or high pressure applications, helping to eliminate fugitive emissions.
- A wide variety of HOKE **GYROLOK**® end fittings or pipe fittings provide the correct fitting option for the application.

### Pressure vs. Temperature Curve

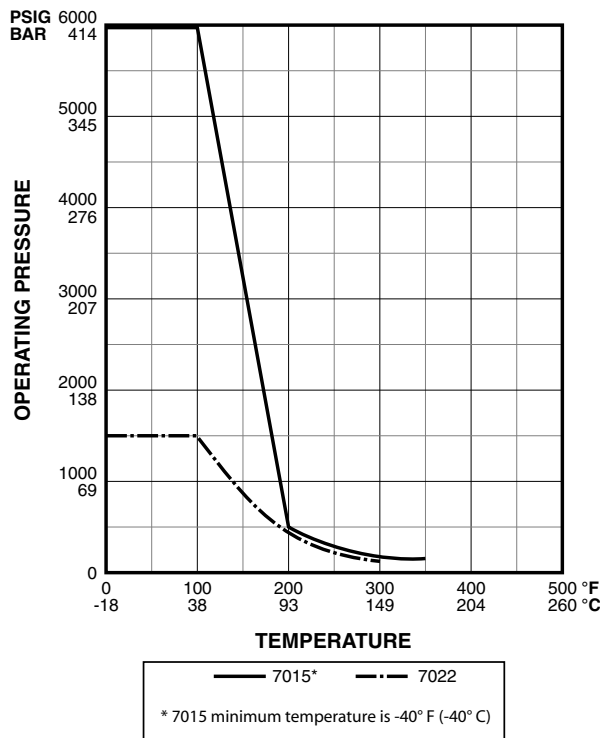

### Flow Diagrams 2-way valve

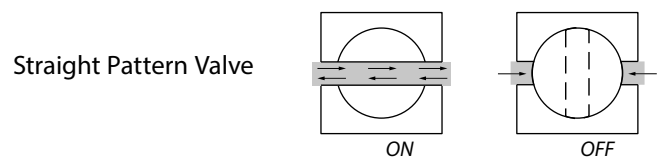

# Ultramite™ 70 Series

## Materials of Construction

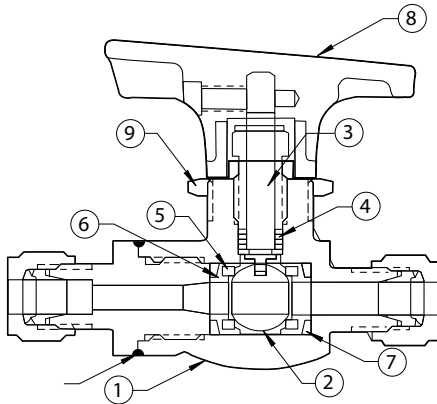

Weld

DESCRIPTION	BRASS	316 ST. STEEL	MONEL®
1 Body	Brass	316 stainless steel	Monel®
2 Ball	316 stainless steel	316 stainless steel	Monel®
3 Stem	316 stainless steel	316 stainless steel	Monel®
4 Stem packing	TFE/316 stainless steel wafers	TFE/316 stainless steel wafers	TFE/Monel® wafers
5 Seats			
7015 Series	—	PCTFE	—
7022 Series	TFE	TFE	TFE
6 Seat retainers	Brass	316 stainless steel	Monel®
7 Seat washers†			
7015 Series	—	Viton®	—
7022 Series	TFE	TFE	TFE
8 Handle	Nylon	Nylon	Nylon
9 Panel mounting nut	Nickel-plated brass	316 stainless steel	Nickel-plated brass

† Other elastomers are available upon request. Contact your local distributor.

## Dimensions

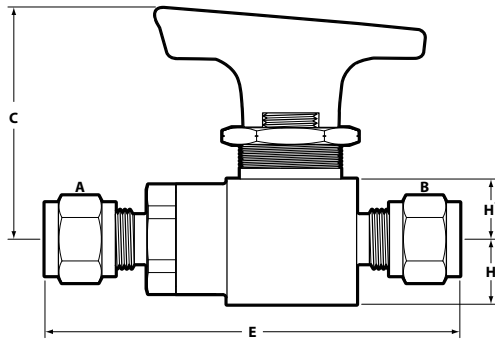

INLET A	OUTLET B	C	E	H	H'	
1/8" GYROLOK®	1/8" GYROLOK®	inch	1 <sup>13</sup> / <sub>32</sub>	2 <sup>19</sup> / <sub>32</sub>	1 <sup>3</sup> / <sub>32</sub>	1 <sup>11</sup> / <sub>32</sub>
		mm	36	66	10	9
1/4" GYROLOK®	1/4" GYROLOK®	inch	1 <sup>3</sup> / <sub>4</sub>	3 <sup>1</sup> / <sub>16</sub>	1/2	7/16
		mm	44	78	13	11
1/4" male NPT	1/4" GYROLOK®	inch	1 <sup>7</sup> / <sub>8</sub>	2 <sup>7</sup> / <sub>8</sub>	1/2	7/16
		mm	48	73	13	11
1/4" male NPT	1/4" male NPT	inch	1 <sup>7</sup> / <sub>8</sub>	2 <sup>17</sup> / <sub>32</sub>	1/2	7/16
		mm	48	64	13	11
1/4" male NPT	1/4" female NPT	inch	1 <sup>7</sup> / <sub>8</sub>	2 <sup>17</sup> / <sub>32</sub>	1/2	7/16
		mm	48	64	13	11
1/4" female NPT	1/4" female NPT	inch	1 <sup>3</sup> / <sub>4</sub>	2 <sup>7</sup> / <sub>16</sub>	1/2	7/16
		mm	44	62	13	11
3/8" GYROLOK®	3/8" GYROLOK®	inch	1 <sup>3</sup> / <sub>4</sub>	3 <sup>7</sup> / <sub>32</sub>	1/2	7/16
		mm	44	82	13	11

### Panel Mounting

Panel hole: for 1/8" GYROLOK® 1<sup>9</sup>/<sub>32</sub>" (15mm) diameter  
for all other models 4<sup>9</sup>/<sub>64</sub>" (19mm) diameter

Panel thickness: for 1/8" GYROLOK® 3/16" (5mm) diameter  
for all other models 1/4" (6mm) diameter

Dimensions for reference only, subject to change.

## How to Order Standard Valves



7022F4B

**Ultramite™ 7015 Series** Pressure to 6000 psig (414 bar), PCTFE Seats—Viton® washers  
Temperature range: -40° F to 300° F (-40° C to +149° C)

END CONNECTIONS		ORDER BY PART NUMBER		ORIFICE	Cv
INLET	OUTLET	316 ST. STEEL			
1/4" GYROLOK®	1/4" GYROLOK®	7015G4Y		0.187	0.80
1/4" male NPT	1/4" GYROLOK®	7015H4Y		0.187	0.80
1/4" male NPT	1/4" female NPT	7015L4Y		0.250	1.40
1/4" female NPT	1/4" female NPT	7015F4Y		0.250	1.40
3/8" GYROLOK®	3/8" GYROLOK®	7015G6Y		0.250	1.40

**Ultramite™ 7022 Series** Pressure to 1500 psig (103 bar), TFE Seats—TFE Washers  
Temperature range: 0° F to 350° F (-18° C to +177° C)

END CONNECTIONS		ORDER BY PART NUMBER			ORIFICE	Cv
INLET	OUTLET	BRASS	316 ST. STEEL	MONEL®		
1/8" GYROLOK®	1/8" GYROLOK®	—	7022G2Y	—	0.093	0.23
1/4" GYROLOK®	1/4" GYROLOK®	7022G4B	7022G4Y	7022G4M	0.187	0.80
1/4" male NPT	1/4" GYROLOK®	—	7022H4Y	—	0.187	0.80
1/4" male NPT	1/4" male NPT	—	7022M4Y	—	0.250	1.40
1/4" male NPT	1/4" female NPT	7022L4B	7022L4Y	—	0.250	1.40
1/4" female NPT	1/4" female NPT	7022F4B	7022F4Y	7022F4M	0.250	1.40
3/8" GYROLOK®	3/8" GYROLOK®	7022G6B	7022G6Y	7022G6M	0.250	1.40

### FOR YOUR SAFETY

IT IS SOLELY THE RESPONSIBILITY OF THE SYSTEM DESIGNER AND USER TO SELECT PRODUCTS SUITABLE FOR THEIR SPECIFIC APPLICATION REQUIREMENTS AND TO ENSURE PROPER INSTALLATION, OPERATION AND MAINTENANCE OF THESE PRODUCTS. MATERIAL COMPATIBILITY, PRODUCT RATINGS AND APPLICATION DETAILS SHOULD BE CONSIDERED IN THE SELECTION. IMPROPER SELECTION OR USE OF PRODUCTS DESCRIBED HEREIN CAN CAUSE PERSONAL INJURY OR PROPERTY DAMAGE.

# Ultramite™ 70 Series

## Ultramite™ 7092, 7093 Series (2-way Valves)

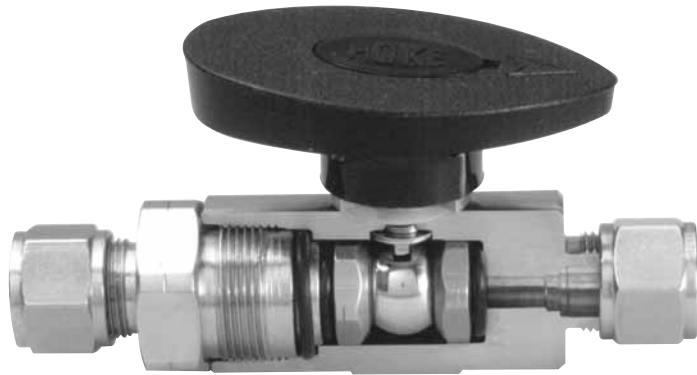

Cv Factor: 3.4

### Features & Benefits

- Fixed end fittings prevent accidental disassembly, enhancing safety.
- Oval trip-proof handle helps prevent accidental actuation. Quarter turn handle provides a visual indication of on/off valve position, providing improved safety.
- Dual encapsulated TFE seats and microfinished ball ensure a leak tight seal. This provides greater valve reliability and operator peace of mind.
- Floating ball provides pressure-assisted sealing and temperature wear compensation for longer valve cycle life and greater value.

### Typical Applications

- Slurry handling
- Refinery pilot plants
- Pneumatic systems
- Corrosives handling

### Technical Data

<b>BODY MATERIAL</b>	316 stainless steel, brass, Monel®
<b>OPERATING PRESSURE RANGE @ 70° F (21° C)</b>	7092 Series Moderate vacuum* to 2000 psig (138 bar) 7093 Series Moderate vacuum* to 5000 psig (345 bar)
<b>OPERATING TEMPERATURE RANGE</b>	-20° F to +350° F (-29° C to +177° C) (both series)
<b>ORIFICE SIZE</b>	0.375" (9.5mm)
<b>Cv FACTOR</b>	3.4
<b>END CONNECTIONS</b>	½" GYROLOK® ⅜" to ½" NPT

\* Moderate vacuum is 10<sup>-3</sup> to 20 torr.

### Pressure vs. Temperature Curve

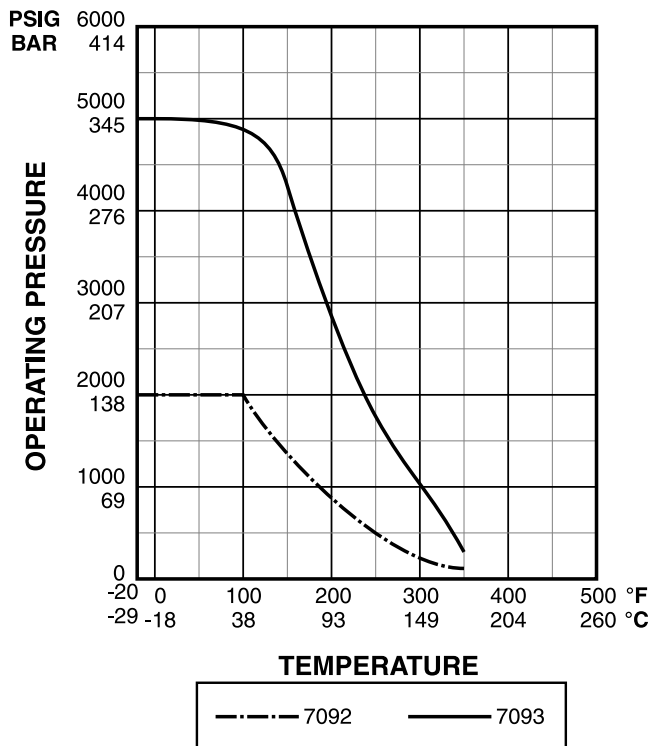

### Flow Diagrams 2-way valve

Straight Pattern Valve

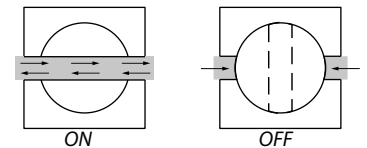

# Ultramite™ 70 Series

## Materials of Construction

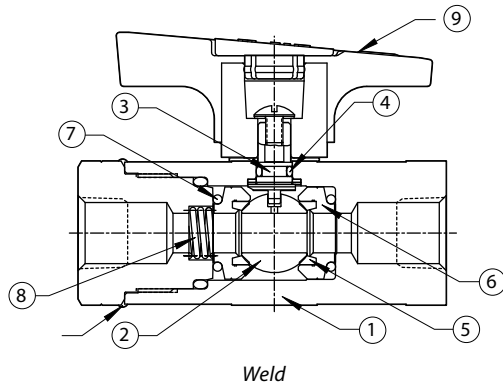

DESCRIPTION	BRASS	316 STAINLESS STEEL	MONEL®
1 Body	Brass	316 stainless steel	Monel®
2 Ball	316 stainless steel	316 stainless steel	Monel®
3 Stem	316 stainless steel	316 stainless steel	Monel®
4 Stem packing†	Viton®	Viton®	Viton®
5 Seats	TFE	TFE	TFE
6 Seat retainers	316 stainless steel	316 stainless steel	Monel®
7 Seat washers† 7092 Series 7093 Series*	TFE —	TFE Viton®	TFE —
8 Spring	316 stainless steel	316 stainless steel	Monel®
9 Handle	Nylon	Nylon	Nylon

† Other elastomers are available upon request. Contact your local distributor

\* 7093 series only available in 316 stainless steel

## Dimensions

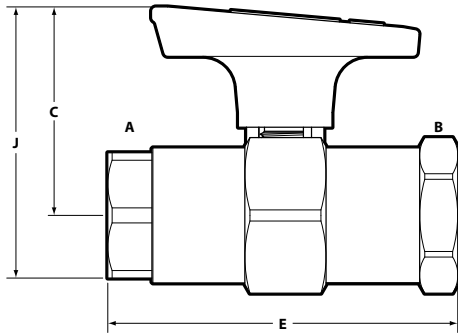

INLET A	OUTLET B		C	E	J
3/8" female NPT	3/8" female NPT	inch	1 7/8	3 1/2	2 9/16
		mm	48	89	65
1/2" female NPT	1/2" female NPT	inch	1 7/8	3 1/2	2 9/16
		mm	48	89	65
1/2" GYROLOK®	1/2" GYROLOK®	inch	1 7/8	4 7/8	2 9/16
		mm	48	124	65

Dimensions for reference only, subject to change.

## Ordering Options



Optional metal lever handle

### Metal Lever Handle

A metal lever handle is available for 7092 and 7093 Series valves. To order, specify 90043-1 with plug button 5982.

### Panel Mounting

Panel mounting is available for 7092 and 7093 valves by specifying kit 7200K1.

## How to Order Standard Valves



7093F8Y

### Ultramite™ 7092 Series Pressure to 2000 psig (138 bar), TFE Seats—TFE Washers

END CONNECTIONS		ORDER BY PART NUMBER				ORIFICE	Cv
INLET	OUTLET	BRASS	316 ST. STEEL	MONEL®			
3/8" female NPT	3/8" female NPT	—	7092F6Y	7092F6M	0.375	3.4	
1/2" female NPT	1/2" female NPT	7092F8B	7092F8Y	7092F8M	0.375	3.4	
1/2" GYROLOK®	1/2" GYROLOK®	7092G8B	7092G8Y	7092G8M	0.375	3.4	

### Ultramite™ 7093 Series Pressure to 5000 psig (345 bar), TFE Seats—Viton® Washers

END CONNECTIONS		ORDER BY PART NUMBER				ORIFICE	Cv
INLET	OUTLET	BRASS	316 ST. STEEL	MONEL®			
3/8" female NPT	3/8" female NPT	—	7093F6Y	7093F6M	0.375	3.4	
1/2" female NPT	1/2" female NPT	—	7093F8Y	7093F8M	0.375	3.4	
1/2" GYROLOK®	1/2" GYROLOK®	—	7093G8Y	7093G8M	0.375	3.4	

### FOR YOUR SAFETY

IT IS SOLELY THE RESPONSIBILITY OF THE SYSTEM DESIGNER AND USER TO SELECT PRODUCTS SUITABLE FOR THEIR SPECIFIC APPLICATION REQUIREMENTS AND TO ENSURE PROPER INSTALLATION, OPERATION AND MAINTENANCE OF THESE PRODUCTS. MATERIAL COMPATIBILITY, PRODUCT RATINGS AND APPLICATION DETAILS SHOULD BE CONSIDERED IN THE SELECTION. IMPROPER SELECTION OR USE OF PRODUCTS DESCRIBED HEREIN CAN CAUSE PERSONAL INJURY OR PROPERTY DAMAGE.

# Ultramite™ 70 Series

## Ultramite™ 7065 Series (3-way Valve)

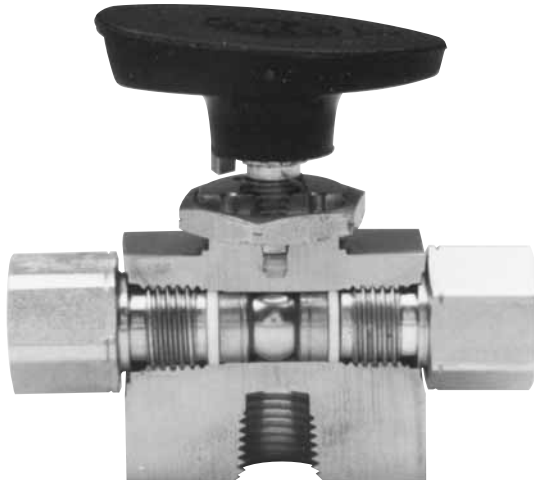

*Cv Factors: 0.15 to 0.57*

The Ultramite™ 7065 3-way ball valve uses 180° handle rotation for diverting flow from one line to another. The oval handle points to the port in use. When the handle is perpendicular to the valve body it is in the shutoff position.

### Typical Applications

- Analyzer labs
- Sampling systems
- Fluid diverting/switching

### Technical Data

<b>BODY MATERIAL</b>	316 stainless steel, brass, Monel®
<b>OPERATING PRESSURE RANGE</b>	Moderate vacuum* to 500 psig @ 70° F (34.5 bar @ 21° C)
<b>OPERATING TEMPERATURE RANGE</b>	0° F to +350° F (-18° C to +177° C)
<b>ORIFICE SIZE</b>	0.187" (4.8mm)
<b>Cv FACTORS</b>	0.15 to 0.57
<b>END CONNECTIONS</b>	1/8" to 3/8" GYROLOK® 1/4" NPT

\* Moderate vacuum is 10<sup>-3</sup> to 20 torr.

### Features & Benefits

- Welded ends secure the end fittings preventing accidental disassembly, enhancing safety.
- Oval trip-proof handle helps prevent accidental actuation for safer operation. The handle also serves as a visual indicator of the port in use, or closed position for increased safety.
- Dyna-Pak® packing provides a leak-tight seal with low operating torque in vacuum or high pressure applications, helping to prevent fugitive emissions.

### Pressure vs. Temperature Curve

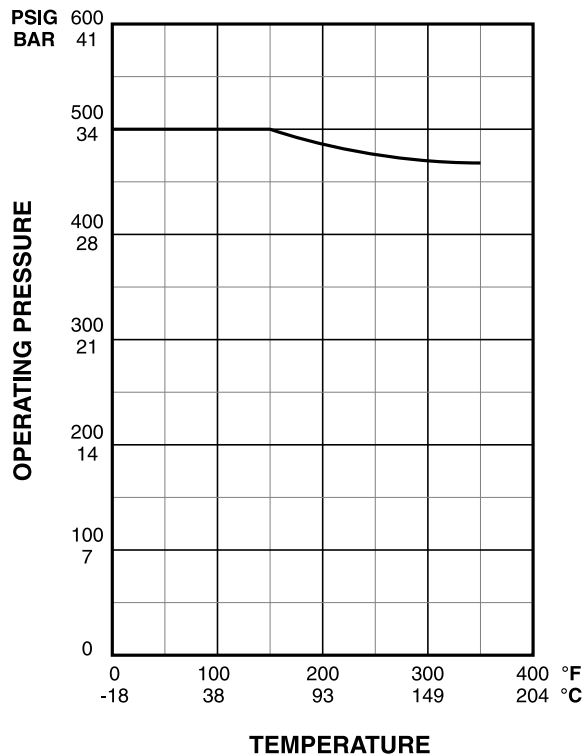

### Flow Diagrams 3-way valve

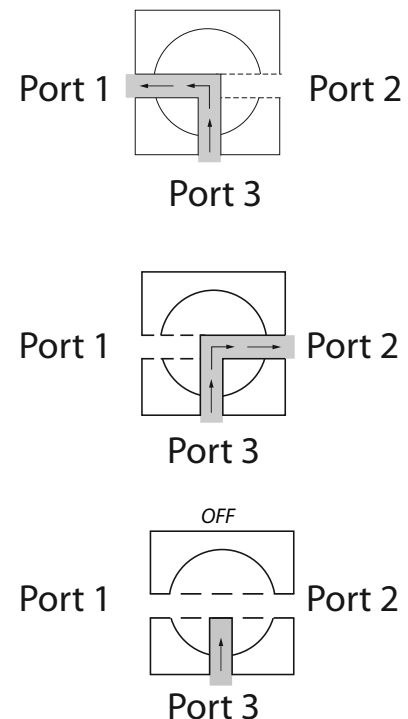

# Ultramite™ 70 Series

## Materials of Construction

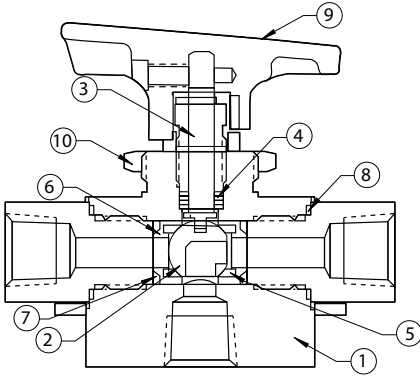

DESCRIPTION	BRASS	316 STAINLESS STEEL	MONEL®
1 Body	Brass	316 stainless steel	Monel®
2 Ball	316 stainless steel	316 stainless steel	Monel®
3 Stem	316 stainless steel	316 stainless steel	Monel®
4 Stem packing	TFE/316 stainless steel wafers	TFE/316 stainless steel wafers	TFE/Monel® wafers
5 Seats	TFE	TFE	TFE
6 Seat retainers	Brass	316 stainless steel	Monel®
7 Seat washers	TFE	TFE	TFE
8 End fittings gaskets	TFE	TFE	TFE
9 Handle	Nylon	Nylon	Nylon
10 Panel mounting nut	Nickel-plated brass	316 Stainless Steel	Nickel-plated brass

## Dimensions

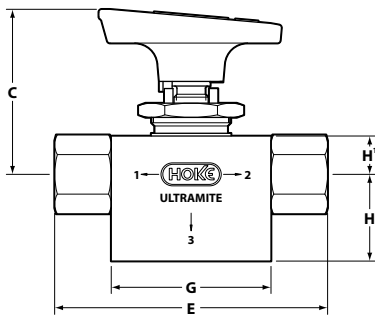

END CONNECTIONS		C	E	G	H	H'
1/8" GYROLOK®	inch	1 <sup>15</sup> / <sub>16</sub>	3 <sup>7</sup> / <sub>16</sub>	1 <sup>3</sup> / <sub>4</sub>	2	7 <sup>1</sup> / <sub>16</sub>
	mm	49	87	44	51	11
1/4" GYROLOK®	inch	1 <sup>15</sup> / <sub>16</sub>	3 <sup>3</sup> / <sub>8</sub>	1 <sup>3</sup> / <sub>4</sub>	2 <sup>1</sup> / <sub>16</sub>	7 <sup>1</sup> / <sub>16</sub>
	mm	49	92	4	52	11
1/4" female NPT	inch	1 <sup>3</sup> / <sub>4</sub>	3	1 <sup>3</sup> / <sub>4</sub>	1 <sup>5</sup> / <sub>16</sub>	7 <sup>1</sup> / <sub>16</sub>
	mm	44	76	44	24	11
3/8" GYROLOK®	inch	1 <sup>15</sup> / <sub>16</sub>	3 <sup>7</sup> / <sub>8</sub>	1 <sup>3</sup> / <sub>4</sub>	2 <sup>3</sup> / <sub>16</sub>	7 <sup>1</sup> / <sub>16</sub>
	mm	49	98	44	56	11

### Panel Mounting

Panel hole: 5<sup>7</sup>/<sub>64</sub>" (23mm) diameter

Panel thickness: 3<sup>1</sup>/<sub>16</sub>" (5mm) diameter

*Dimensions for reference only, subject to change.*

## How to Order



7065F4Y

### Ultramite™ 7065 Series Pressure to 500 psig (35 bar)

END CONNECTIONS		ORDER BY PART NUMBER				
INLET	OUTLET	BRASS	316 ST. STEEL	MONEL®	ORIFICE	Cv
1/8" GYROLOK®	1/8" GYROLOK®	7065G2B	7065G2Y	—	0.093	0.15
1/4" GYROLOK®	1/4" GYROLOK®	7065G4B	7065G4Y	7065G4M	0.187	0.57
1/4" female NPT	1/4" female NPT	7065F4B	7065F4Y	7065F4M	0.187	0.57
3/8" GYROLOK®	3/8" GYROLOK®	7065G6B	7065G6Y	7065G6M	0.187	0.57

#### FOR YOUR SAFETY

IT IS SOLELY THE RESPONSIBILITY OF THE SYSTEM DESIGNER AND USER TO SELECT PRODUCTS SUITABLE FOR THEIR SPECIFIC APPLICATION REQUIREMENTS AND TO ENSURE PROPER INSTALLATION, OPERATION AND MAINTENANCE OF THESE PRODUCTS. MATERIAL COMPATIBILITY, PRODUCT RATINGS AND APPLICATION DETAILS SHOULD BE CONSIDERED IN THE SELECTION. IMPROPER SELECTION OR USE OF PRODUCTS DESCRIBED HEREIN CAN CAUSE PERSONAL INJURY OR PROPERTY DAMAGE.

## Ultramite™ 70 Series Ball Valve Options

### Handle Locking Kit

Safety lockout kits are available for applications which must conform to Code of Federal Regulations 29CFR Part 1910, OSHA

Safety and Health Act, and other international regulations. Valves can be locked in either an opened or closed position with the stainless steel upper and lower locking plates. Lock with readily available padlocks or commercially available multiple lockout devices. Locking kits include the locking plates and assembly instructions. To order a safety lockout kit for Ultramite™ 7015 and 7022 Series valves, specify kit 7100K18; for Ultramite™ 7092 and 7093 Series valves, specify kit 7200K7; for 7065 Series valve, specify kit 7600K1.

### Cleaning and Testing

When ordering, please specify if oxygen cleaning or helium leak testing is required.

### Additional Sizes

Additional sizes and options are available on special request. Please consult your local HOKE distributor.