



Space Saver™ Actuators

Air Actuated 0700 Series



Space Saver™



CRANE Instrumentation & Sampling, HOKE®
PO Box 4866 • Spartanburg, SC 29305-4866
(864) 574-7966 • www.hoke.com

For Your Safety

It is solely the responsibility of the system designer and user to select products suitable for their specific application requirements and to ensure proper installation, operation, and maintenance of these products. When selecting products, the total system design must be considered to ensure safe, trouble-free performance. Material compatibility, product ratings and application details should be considered in the selection. Improper selection or use of products described herein can cause personal injury or property damage.

Contact your authorized HOKE® sales and service representative for information about additional sizes and special alloys.

SAFETY WARNING:

HOKE® products are designed for installation only by professional suitably qualified licensed system installers experienced in the applications and environments for which the products are intended. These products are intended for integration into a system. Where these products are to be used with flammable or hazardous media, precautions must be taken by the system designer and installer to ensure the safety of persons and property. Flammable or hazardous media pose risks associated with fire or explosion, as well as burning, poisoning or other injury or death to persons and/or destruction of property. The system designer and installer must provide for the capture and control of such substances from any vents in the product(s). The system installer must not permit any leakage or uncontrolled escape of hazardous or flammable substances. The system operator must be trained to follow appropriate precautions and must inspect and maintain the system and its components including the product(s) and at regular intervals in accordance with timescales recommended by the supplier to prevent unacceptable wear or failure.



Space Saver™

Air Actuated 0700 Series

This line of space saving pneumatic actuators is designed to provide safe, reliable control of most HOKE® Flomite®, Selectomite®, and DL/TL ball valves. For added flexibility, Space Saver actuators may be operated with many types of clean gases including air, natural gas, and nitrogen. Spring return and double acting versions are available for either 90° or 180° actuation. All Space Saver actuators come standard with a manual override feature for emergency operation.



Typical Applications

- Chemical
- Petrochemical
- Oil and Gas Drilling
- Research and Development
- Environmental Control
- Instrumentation Panels

Technical Data

| | |
|-----------------------------|--|
| Housing Material | Electroless nickel plated aluminum |
| Maximum Operating Pressure | 125 psig (9 bar) |
| Air Supply Connection* | ½ Female NPT |
| Operating Temperature Range | A6L Actuators– -40° to 250° F (-40° to 121° C) A6H Actuators– 0° to 400° F (-18° to 204° C) |
| Cycle time** | 1 second (dependent on air supply) |
| Cycle Life | 250,000 cycles minimum |
| Weight | 1.7 lbs. (0.75 kg) |

* The air line supplying and venting the actuator must not restrict airflow. Orifice size of air supply valves should be 3/32" minimum (2.4 mm) to assure full actuator torque output.

** Cycle time should not exceed 10 cycles per minute when operating continuously. DL or TL ball valves are recommended for higher cycle times.

Features & Benefits

Saves space

- Compact dimensions (2.25" x 2.75" x 3.5")
- One Space Saver actuator can operate two valves simultaneously
- HOKE® DL and TL ball valves are available for high cycle applications
- Available as 90°/180° spring return and double acting
- Operates with many clean gases (air, natural gas, nitrogen) for added flexibility
- Minimal number of moving parts for reduced maintenance
- Corrosion resistant Electroless nickel plated aluminum housing for added durability
- High burst strength for enhanced safety
- Manual override for emergency operation
- Rapid response time of one second or less per cycle
- Unique piston gear drive assembly allows for wide range of uses
- Choice of two operating temperature ranges (A3, A5 models)
- Special High Tolerance NPT Thread

Space Saver™

Space Saver™

Specifications

Materials of Construction

- Electroless Nickel Plated Body
- Anodized aluminum and PTFE coated geared piston
- 316 stainless steel geared output shaft
- Filled PTFE shaft bearing
- Nitrile seals (A6L models)
- Viton® seals (A6H models)
- Alloy steel springs with corrosion resistant coating

Torque Specifications

0713A6L/H 180° Spring Return

| INLET PRESSURE (PSIG/BAR) | AIR SIDE TORQUE OUTPUT (IN/LBS / NM) | | SPRING SIDE TORQUE OUTPUT (IN/LBS / NM) | |
|---------------------------|--------------------------------------|---------|---|---------|
| | AIR START | AIR END | AIR START | AIR END |
| 50/3 | 18/2 | 7/1 | 16/2 | 6/1 |
| 60/4 | 23/3 | 13/2 | 16/2 | 6/1 |
| 70/5 | 28/3 | 17/2 | 16/2 | 6/1 |
| 80/6 | 34/4 | 22/3 | 16/2 | 6/1 |
| 90/6 | 42/5 | 27/3 | 16/2 | 6/1 |
| 100/7 | 46/5 | 31/4 | 16/2 | 6/1 |
| 120/8 | 56/6 | 42/5 | 16/2 | 6/1 |

Minimum inlet pressure to obtain 180° rotation = 50 psig (3 bar)

0713A6L/H, 0722A6L/H 90° Spring Return

| INLET PRESSURE (PSIG) | AIR SIDE TORQUE OUTPUT (IN/LBS / NM) | | SPRING SIDE TORQUE OUTPUT (IN/LBS / NM) | |
|-----------------------|--------------------------------------|---------|---|---------|
| | AIR START | AIR END | AIR START | AIR END |
| 60 | 9/1 | 5/1 | 30/3 | 20/2 |
| 70 | 16/2 | 10/1 | 30/3 | 20/2 |
| 80 | 20/2 | 13/2 | 30/3 | 20/2 |
| 90 | 26/3 | 18/2 | 30/3 | 20/2 |
| 100 | 30/3 | 20/2 | 30/3 | 20/2 |
| 120 | 40/5 | 30/3 | 30/3 | 20/2 |

Minimum inlet pressure to obtain 90° rotation = 60 psig (4 bar)

0750 (180°), 0760 (90°) Double Acting

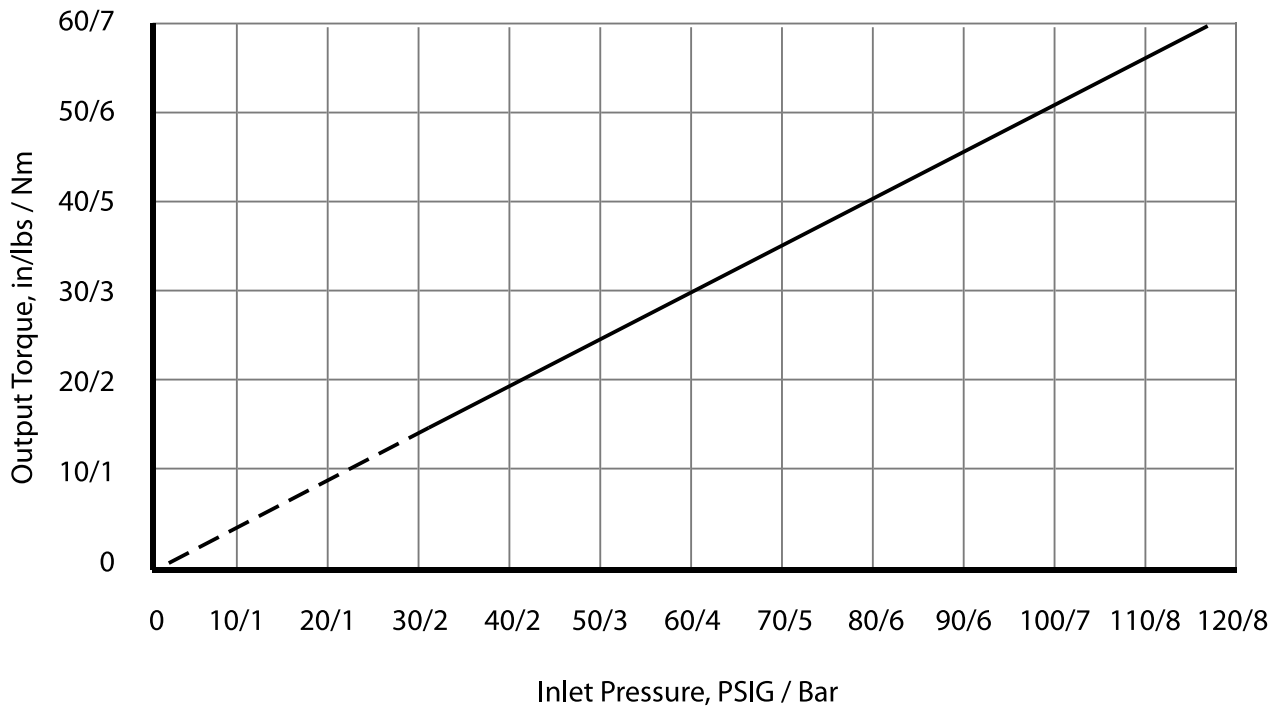

Space Saver™

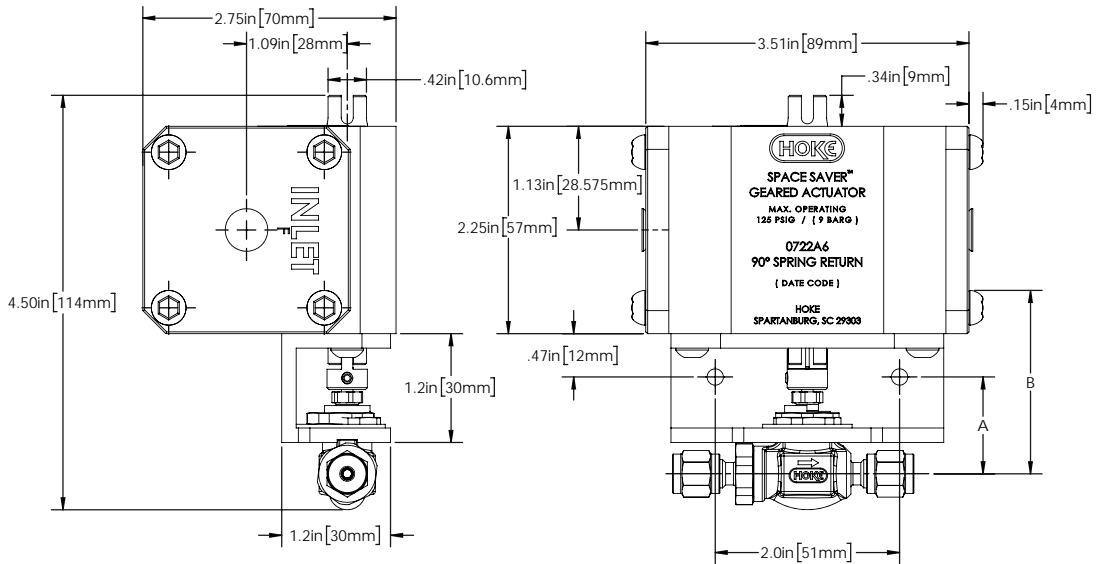

These diagrams above and table below show mounting dimensions and specifications for Space Saver actuators with 1- and 2-valve configurations. All Space Saver actuators and mounting bracket dimensions above are the same across all models.

Mounting Dimensions

| SPACE SAVER P/N | 1 BALL VALVE | 2 BALL VALVES | A | B |
|---------------------------------|--------------|---------------|--------------------|---------------------|
| 0722A6L/H 90° Spring Return | 7142 | 7142 | $\frac{59}{64}$ " | $1 \frac{57}{64}$ " |
| | 7155 | 7155 | 23 mm | 48 mm |
| | 7115 | --- | $1 \frac{1}{32}$ " | 2" |
| 0713A6L/H 180° Spring Return | 7122 | 7122 | 26 mm | 50.8 mm |
| | 7177 | 7177 | $\frac{59}{64}$ " | $1 \frac{57}{64}$ " |
| 0760A6L/H 90° Double Acting | 7165 | --- | 1" | $1 \frac{31}{32}$ " |
| | 7142 | 7142 | $\frac{59}{64}$ " | $1 \frac{57}{64}$ " |
| 0750A6L/H 180° Double Acting | 7155 | 7155 | 23 mm | 48 mm |
| | 7115 | --- | $1 \frac{1}{32}$ " | 2" |
| | 7122 | 7122 | 26 mm | 51 mm |
| 0750A6L/H 180° Double Acting | 7177 | 7177 | $\frac{59}{64}$ " | $1 \frac{57}{64}$ " |
| | 7671 | 7671 | 1" | $1 \frac{31}{32}$ " |
| | 7673 | 7673 | 25 mm | 50 mm |
| | 7165 | 7165 | | |

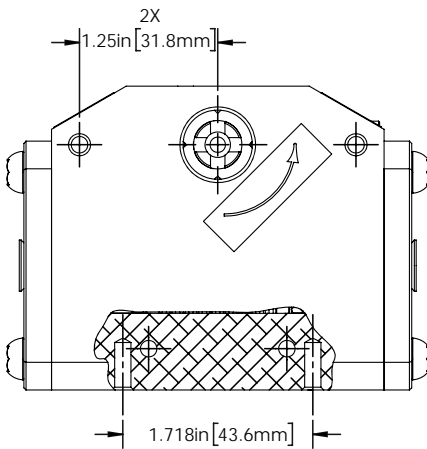

0700 Series Actuator Front View

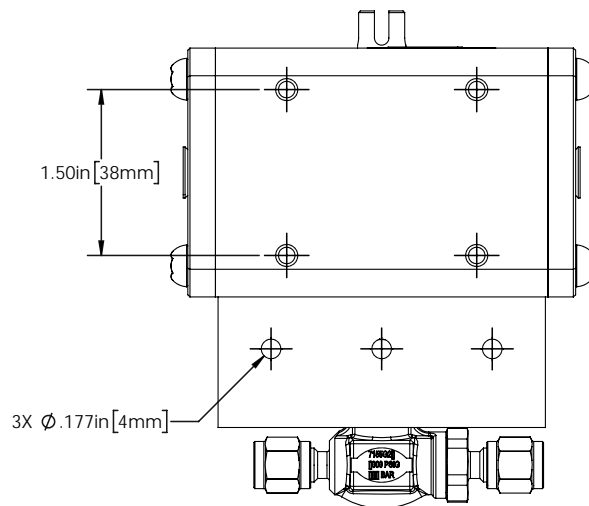

0700 Series Actuator End View

Space Saver™

The 0700 Series single actuator offers the capability of operating up to two 2-way ball valves simultaneously.

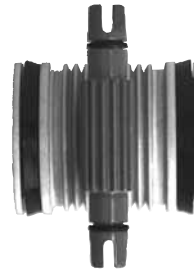

Cut-away of 0700 Series showing unique piston/gear drive assembly design.

How to Order

| NUMBER OF VALVES PER ACTUATOR* | ACTUATOR TYPE | SPACE SAVER PART NUMBER | USE WITH BALL VALVE PART NUMBER** | MOUNTING KIT NUMBER | REQUIRED ACTUATION PRESSURE |
|--------------------------------|--------------------|-------------------------|-----------------------------------|---------------------|-----------------------------|
| 1 | 180° Double Acting | 0750A6L/H | 7165 □ □ □ | 0700K1 | 30 psig (2 bar) |
| | | 0750A6L/H | 7671 □ □ □ | 0700K1 | 40 psig (2 bar) |
| | | 0750A6L/H | 7673 □ □ □ | 0700K1 | 40 psig (2 bar) |
| | | 0750A6L/H | 7177 □ □ □ | 0700K2 | 20 psig (1 bar) |
| 2* | 180° Double Acting | 0750A6L/H | 7165 □ □ □ | 0700K1 | 50 psig (3 bar) |
| | | 0750A6L/H | 7671 □ □ □ | 0700K1 | 60 psig (4 bar) |
| | | 0750A6L/H | 7673 □ □ □ | 0700K1 | 60 psig (4 bar) |
| | | 0750A6L/H | 7177 □ □ □ | 0700K2 | 25 psig (2 bar) |
| 1 | 180° Spring Return | 0713A6L/H | 7165 □ □ □ | 0700K1 | 60 psig (4 bar) |
| | | 0713A6L/H | 7177 □ □ □ | 0700K2 | 40 psig (2 bar) |
| 2* | 180° Spring Return | 0713A6L/H | 7177 □ □ □ | 0700K2 | 50 psig (3 bar) |
| | | | | | |
| 1 | 90° Spring Return | 0722A6L/H | 7115 □ □ □ | 0700K3 | 80 psig (6 bar) |
| | | 0722A6L/H | 7122 □ □ □ | 0700K3 | 70 psig (5 bar) |
| | | 0722A6L/H | 7142 □ □ □ | 0700K2 | 60 psig (4 bar) |
| | | 0722A6L/H | 7155 □ □ □ | 0700K2 | 65 psig (4 bar) |
| 2* | 90° Spring Return | 0722A6L/H | 7122 □ □ □ | 0700K3 | 90 psig (6 bar) |
| | | 0722A6L/H | 7142 □ □ □ | 0700K2 | 70 psig (5 bar) |
| | | 0722A6L/H | 7155 □ □ □ | 0700K2 | 75 psig (5 bar) |
| | | 0722A6L/H | — | 0700K3 | 80 psig (6 bar) |
| 1 | 90° Double Acting | 0760A6L/H | 7115 □ □ □ DL □ | 0700K3 | 80 psig (6 bar) |
| | | 0760A6L/H | 7122 □ □ □ T L □ | 0700K3 | 70 psig (5 bar) |
| | | 0760A6L/H | 7022 □ □ □ T L □ | 0700K3 | 70 psig (5 bar) |
| 1 | 90° Double Acting | 0760A6L/H | 7115 □ □ □ | 0700K3 | 30 psig (2 bar) |
| | | 0760A6L/H | 7122 □ □ □ | 0700K3 | 25 psig (2 bar) |
| | | 0760A6L/H | 7142 □ □ □ | 0700K2 | 20 psig (1 bar) |
| | | 0760A6L/H | 7155 □ □ □ | 0700K2 | 20 psig (1 bar) |
| 2* | 90° Double Acting | 0760A6L/H | — | 0700K3 | 30 psig (2 bar) |
| | | 0760A6L/H | 7122 □ □ □ | 0700K3 | 25 psig (2 bar) |
| | | 0760A6L/H | 7142 □ □ □ | 0700K2 | 20 psig (1 bar) |
| | | 0760A6L/H | 7155 □ □ □ | 0700K2 | 20 psig (1 bar) |

* Two valve mounting kits required for two valve operation.

** 7165, 7177, and 7673 Series not recommended for high cycle applications.

FACTORY ASSEMBLY

To order factory assembled, additional information is required

- For Spring Return 90° actuators, normally open or normally closed must be specified.
- For Spring Return 180° actuators, spring return position must be indicated on order.
- Order must also state “factory assembled.”
- For general ball valve model numbers, please see above or page 3. For specific information on ball valves, refer to HOKE®’s High Cycle Ball Valve Catalog #79067. DL or TL Series ball valves should be used for high cycle applications.
- Example: **0722A6L/H** normally open actuator with **7115G6Y** ball valve and **0700K3** mounting kit, factory assembled.

Field Assembly

To order the valve and actuator for field assembly, the valve number, actuator number and mounting kit number must be specified. Example: **7122F4Y TL** ball valve with **0722A6L/H** actuator and **0700K3** Mounting Kit, for field assembly.

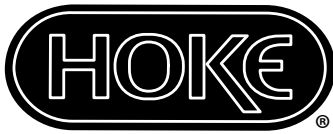

The Small Bore Instrumentation Specialists



We specialize in small bore instrumentation products up to 2" that deliver benchmark performance quality & safety; provide the broadest array of superior alloy offerings in the market; decades of proven success in a wide range of industries; a roster of "who's who" customers & projects globally; original "Best Solution" engineering & designs; and are focused on continuous improvement in all aspects of our business.

Proudly Distributed By:



CRANE INSTRUMENTATION &
SAMPLING Inc.
405 Centura Ct.
Spartanburg, SC 29305, USA
Tel: 1-864-574-7966
PO Box 4866, Spartanburg, SC
29305-4866 USA

Crane Co., and its subsidiaries cannot accept responsibility for possible errors in catalogues, brochures, other printed materials, and website information. Crane Co. reserves the right to alter its products without notice, including products already on order provided that such alteration can be made without changes being necessary in specifications already agreed. All trademarks in this material are the property of the Crane Co. or its subsidiaries. The Crane and Crane brands logotype (CENTER LINE®, COMPAC-NOZ®, CRANE®, DEPA® & ELRO®, DOPAK®, DUO-CHEK®, FLOWSEAL®, GYROLOK®, GO REGULATOR®, HOKE®, JENKINS®, KROMBACH®, NOZ-CHEK®, PACIFIC VALVES®, RESISTOFLEX®, REVO®, SAUNDERS®, STOCKHAM®, TEXAS SAMPLING®, TRIANGLE®, UNI-CHEK®, VALVES®, WTA®, and XOMOX®) are registered trademarks of Crane Co. All rights reserved.