

4100 Series

316 Stainless Steel or Brass Bellows Sealed Valves
(.060"/1.5 mm or .170"/4.3 mm orifices)

Introduction

With its compact size suitable for confined spaces, the 4100 Series design includes an internal volume of only 0.08 cubic inches. Brass and 316 stainless steel bodies are available. Operating pressures range from 0 - 600 psig (brass) and 0-1000 psig (stainless steel). 316 stainless steel operating temperature ratings range from -40° to +600° F (-40° to +316° C), while the brass operating temperature range is -40° to +300° F (-40° to +149° C) depending on whether a hard or soft seat is selected.

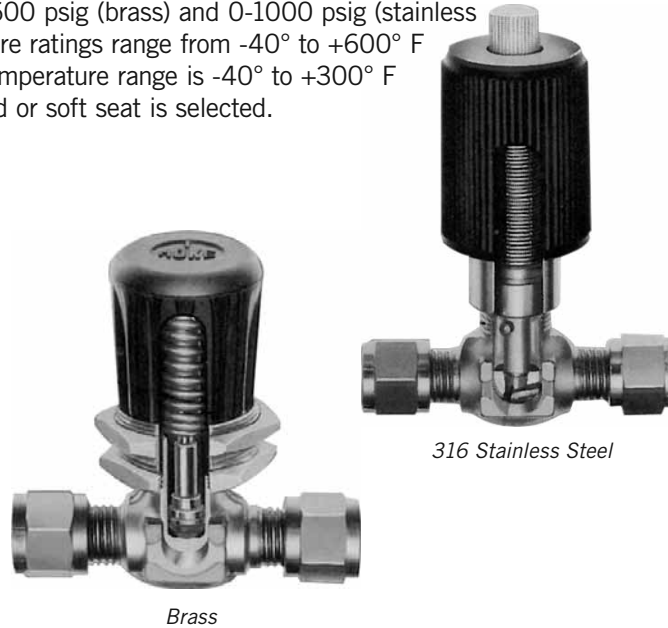

Brass

316 Stainless Steel

Typical Applications

Stainless steel valves

- Critical gas analysis
- High temperature liquid metals
- Handling reactive and toxic fluids
- Vacuum system bake-out

Brass valves

- Sampling systems
- Gas analysis equipment
- Laboratory service
- Instrumentation

Features & Benefits

- Low internal volume for gas analysis
- Panel mounting is available (specify kit 4100K1)

Stainless steel valves

- Choice of blunt or regulating stem points
- Seal welded bellows to body

Brass valves

- Phosphor bronze bellows silver-soldered to body and stem isolates fluid from atmosphere
- Choice of vee stem with small orifice for metering, blunt point, or PCTFE stem
- Special High Tolerance NPT Thread

Technical Data

	316 STAINLESS STEEL	BRASS
MAXIMUM OPERATING PRESSURE	Vacuum to 1000 psig (70 kg/cm ²)	Vacuum to 600 psig @ 70° F (45 kg/cm ² @ 21° C)
TEMPERATURE RANGE	-40° F to +600° F (-40° C to +316° C)	Hard seat: -40° F to +300° F (-40° C to +149° C) Soft seat: -40° F to +250° F (-40° C to +121° C)
ORIFICE SIZE	Vee stem: 0.059 (1.5 mm) Blunt stem: 0.170 (4.3 mm)	Vee stem: 0.060 (1.5 mm) Blunt stem: 0.170 (4.3 mm) PCTFE stem: 0.170 (4.3 mm)
Cv FACTOR	0.35 (maximum)	0.35 (maximum)
INTERNAL VOLUME	0.08 cubic inches	0.08 cubic inches

packless valves

4100 Series

Materials of Construction

316 Stainless Steel

	DESCRIPTION	MATERIAL
1	Body	316 stainless steel
2	Cap nut	Brass, nickel-plated
3	Handle	Brass, nickel-plated
4	Bellows	316 stainless steel
5	Stem point	316 stainless steel
6	Panel mounting kit	Brass, nickel-plated

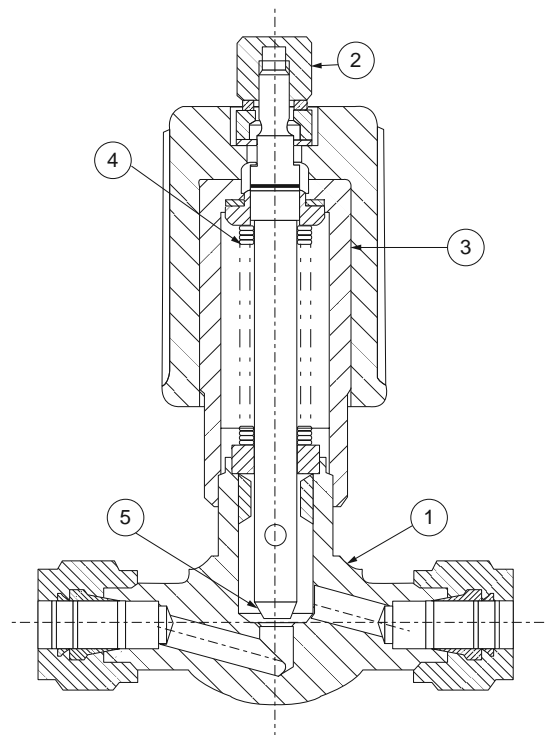

Materials of Construction

Brass

	DESCRIPTION	MATERIAL
1	Body	Forged brass
2	Bellows	Phosphor bronze silver-soldered to body
3	Stem	316 stainless steel
4	Stem tip	PCTFE
5	Handle	Nylon with brass insert

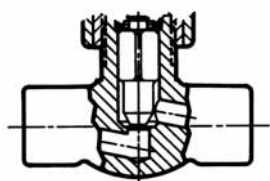

Blunt Stem
4111M4B

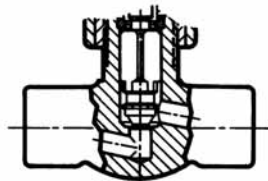

PCTFE Stem
4151M4B

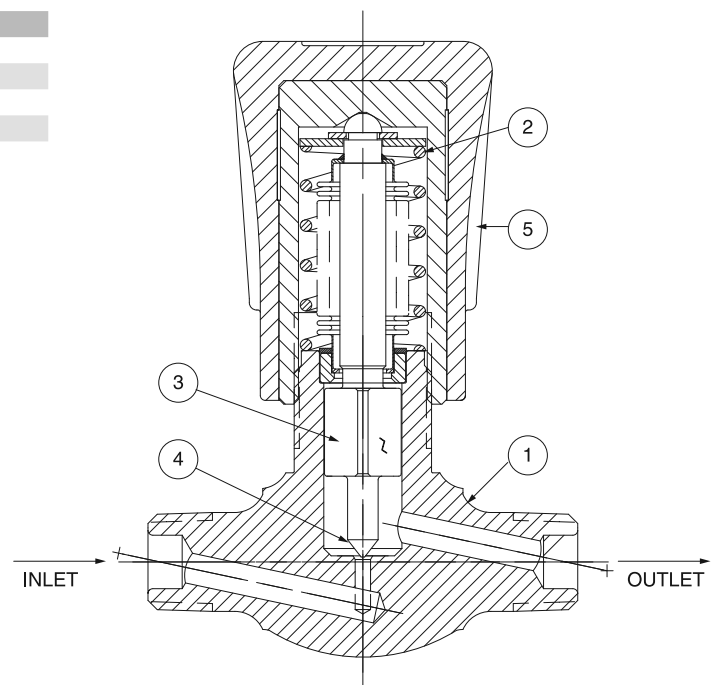

Vee Stem
4171M4B

4100 Series

Dimensions

Stainless Steel

CONNECTIONS		D	E	F	H	H1	PANEL MOUNTING	
							HOLE SIZE	MAX. THICKNESS
1/4" NPT Male	inch	3	1 3/4	1	25/64	1 1/2	1 1/4	1/4
	mm	76	44	25	10	9	26	6
1/4" O.D. Tube GYROLOK®	inch	3	2 3/8	1	25/64	1 1/2	1 1/4	1/4
	mm	76	60	25	10	9	26	6
6 mm GYROLOK®	inch	3	2 3/8	1	25/64	1 1/2	1 1/4	1/4
	mm	76	60	25	10	9	26	6

Dimensions for reference only, subject to change.

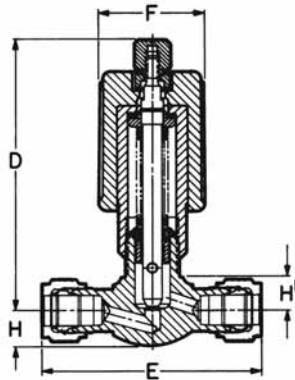

Blunt Stem
4112G4Y

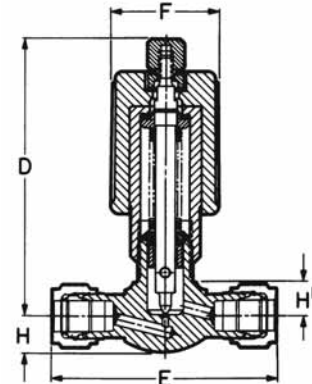

Vee Stem
4172G4Y

Dimensions

Brass

CONNECTIONS		D	E	F	H	H1	PANEL MOUNTING	
							HOLE SIZE	MAX. THICKNESS
1/8" NPT Male	inch	2 5/8	1 3/4	1 1/16	23/64	3/8	1 1/4	1/4
	mm	67	44	27	9	10	26	6
1/4" NPT Male	inch	2 5/8	1 3/4	1 1/16	23/64	3/8	1 1/4	1/4
	mm	67	44	27	9	10	26	6
1/4" O.D. Tube GYROLOK®	inch	2 5/8	1 3/4	1 1/16	23/64	3/8	1 1/4	1/4
	mm	67	60	27	9	10	26	6

Dimensions for reference only, subject to change.

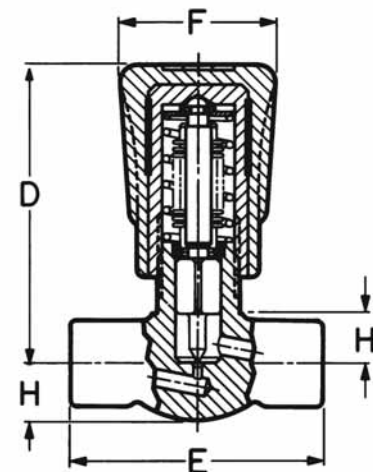

Vee Stem
4171M4B

4100 Series

How to Order

Stainless Steel: Order valve by part number shown in chart.

ORDER BY PART NUMBER					
CONNECTIONS	BLUNT STEM	VEE STEM	CV FACTOR	ORIFICE	
¼" NPT Male	4112M4Y	—	0.35	0.17	
¼" O.D. Tube GYROLOK®	—	4172G4Y	0.059	0.06	
¼" O.D. Tube GYROLOK®	4112G4Y	—	0.35	0.17	
6 mm GYROLOK®	4112G6Y/MM	—	0.35	0.17	
6 mm GYROLOK®	—	4172G6Y/MM	0.059	0.06	
Panel Mounting Kit	4100K1	4100K1	—	—	

Brass: Order valve by part number shown in chart.

ORDER BY PART NUMBER					
CONNECTIONS	BLUNT STEM	VEE STEM	PCTFE STEM	CV FACTOR	ORIFICE
½" NPT Male	4111M2B	—	4151M2B	0.35	0.17
½" NPT Male	—	4171M2B	—	0.059	0.06
½" NPT Male x 1/8" NPT Female	4111L2B	—	—	0.35	0.17
¼" NPT Male	4111M4B	—	4151M4B	0.35	0.17
¼" NPT Male	—	4171M4B	—	0.059	0.06
¼" O.D. Tube GYROLOK®	—	—	4151G4B	0.35	0.17

Panel Mounting

To order Panel Mounting Kit, specify part number **4100K1**.